

X:\dhyikema\Land Projects R2\Const Details\dwg\2004 City\013_DTL_2004.dwg 3/28/2008

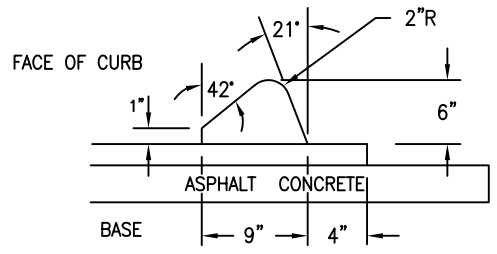

TYPE 1

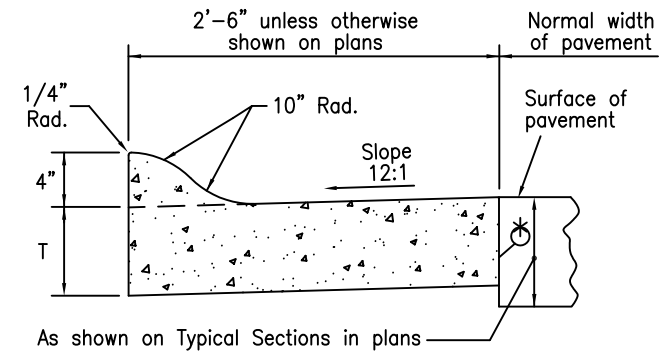

TYPE 3

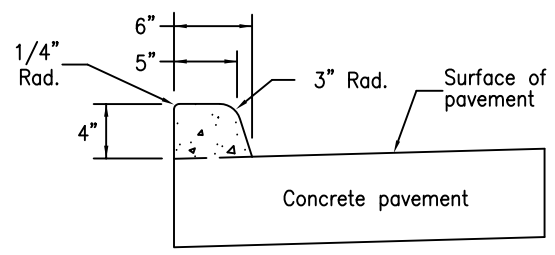

TYPE 4-A

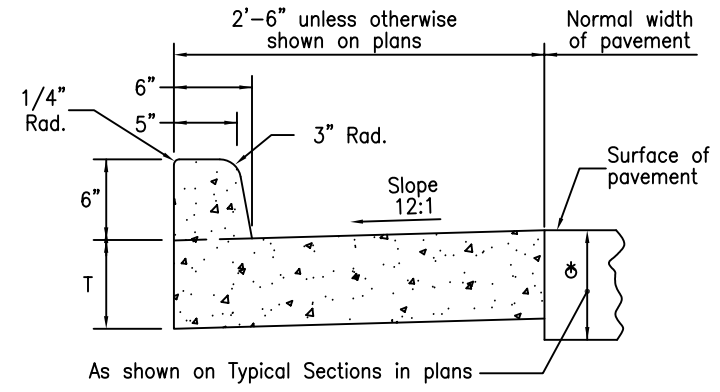

TYPE 2

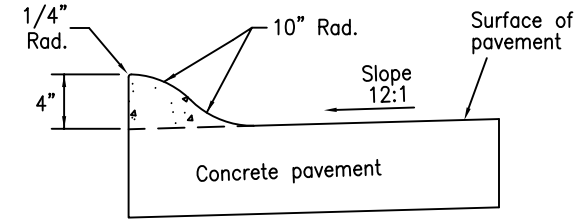

TYPE 3-A

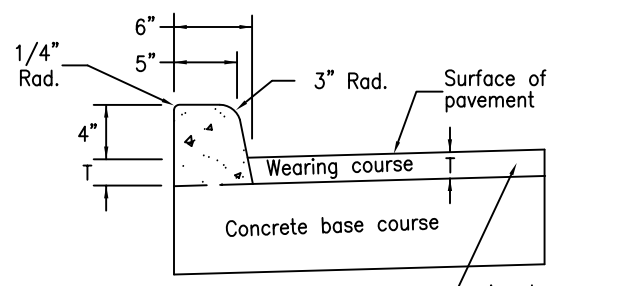

TYPE 4-B

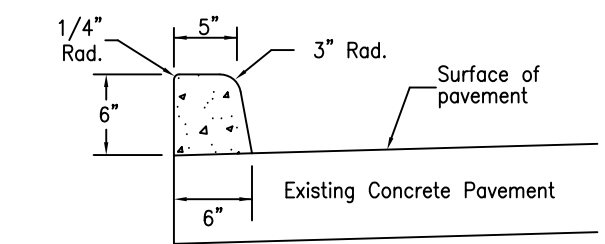

TYPE 2-A

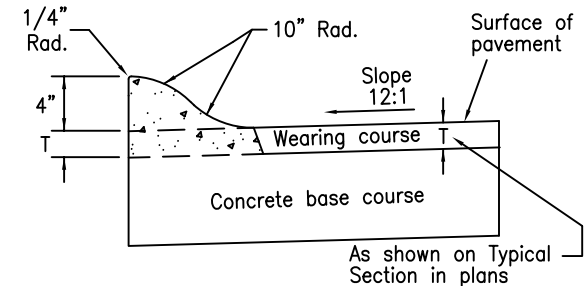

TYPE 3-B

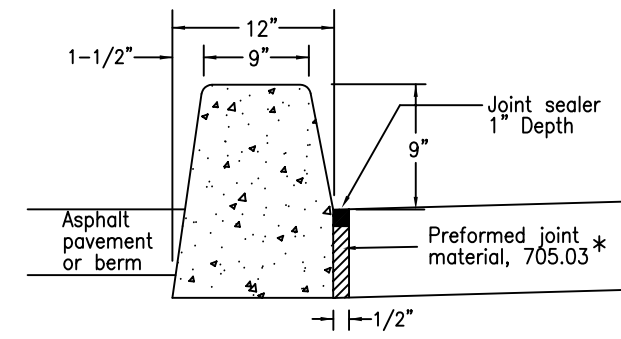

TYPE 8

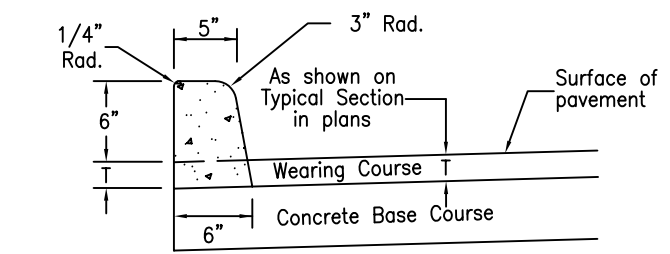

TYPE 2-B

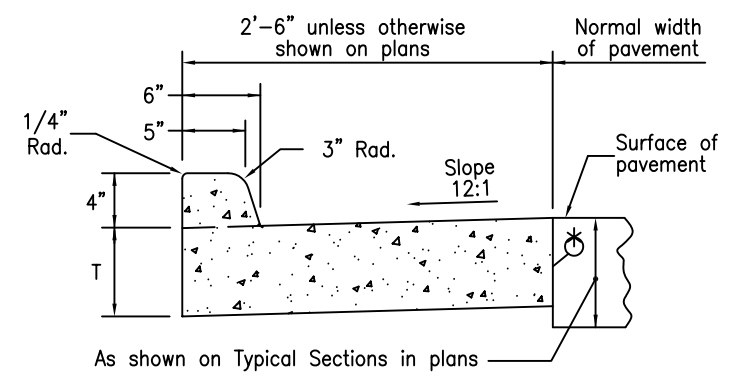

TYPE 4

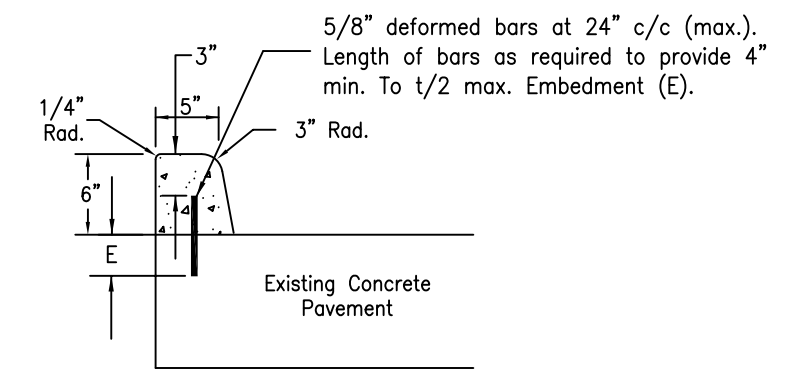

TYPE 2-A MODIFIED

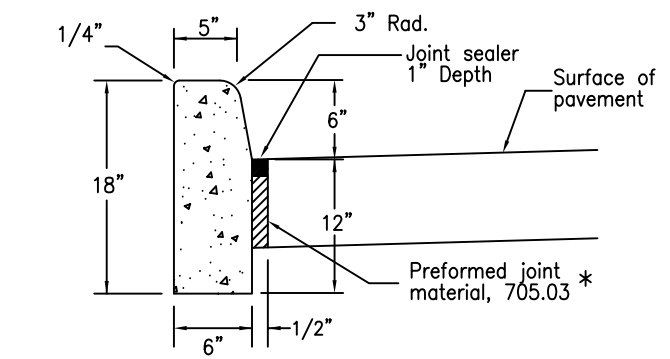

TYPE 6

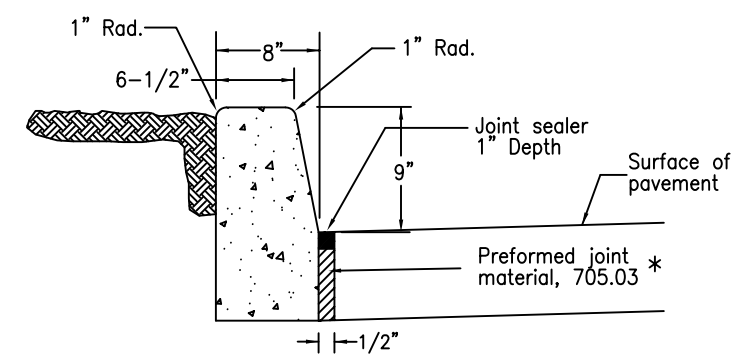

TYPE 7

NOTES

GENERAL: This drawing shows alternate types of curb that may be used on various types of pavement. Typical section of project shows the type to be used, also the thickness of the edge of the pavement or the edge of the curb and gutter section.

JOINTS: One inch expansion joint shall extend up to the top of the curb and shall be constructed in the curb and gutter section in such a manner that the joint seal will extend the full width of the gutter and into the curb face a sufficient distance to seal the joint to an elevation of at least 2" above the flow line of the gutter. Dowel bars shall be used in the curb and gutter section at expansion joints which are identical with the joints in the pavement. All joints shall be constructed perpendicular to the edge of the curb and to the surface of the pavement.

Transverse expansion joint material shall meet the requirements of Item 705.03.

GUTTER PLATE THICKNESS: Thickness of the gutter plate "T" shall be 9" unless otherwise shown on the plans.

TOLERANCES in the dimensions are as follows:
Curbs: -1/32" to +1/4", Gutters 0 to +1/2".

* Expansion joint material and joint sealer is not required for that portion of the curb which is adjacent to a flexible type pavement. Both materials are required as detailed for the full height of rigid pavement and concrete bases.

Ø Butt joints shall be provided between combined curb-and-gutter and new or existing rigid pavements, with tie bars or hook bolts provided at intervals of 5 feet. See O.D.O.T. Std. BP-2.1 for details of tie bars and hook bolts.

If the combined curb-and-gutter adjoins a new rigid base or an existing rigid base or pavement that is to be surfaced with bituminous material, a butt joint shall also be provided. However, tie bars or hook bolts shall be omitted when the vertical overlap ("V" in detail below) between the curb-and-gutter and rigid pavement is less than 7 inches.

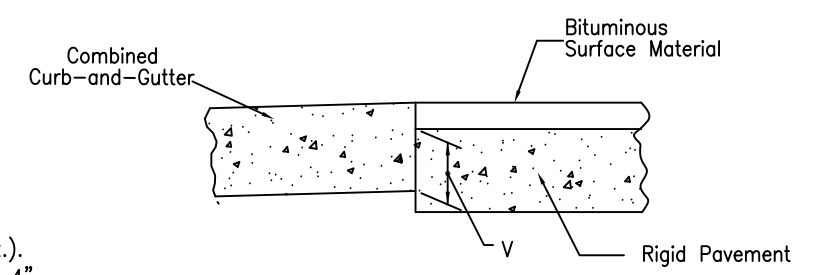

1	1/16/04	DAH	General Revisions - Re-Issued
REV No.	DATE	BY	DESCRIPTION
CITY OF WESTLAKE, OHIO DEPARTMENT OF ENGINEERING			
CONCRETE CURBS & CURB & GUTTER			
SCALE:	AS NOTED		13
DATE:	DRWN BY:		